

SH. 1  
OF 1

CAT NO

655-441/J

CUSTOMER DIMENSIONS

DO NOT  
SEPARATE  
PRINT FROM  
WORK

LOT NO

OPER

TOOLS

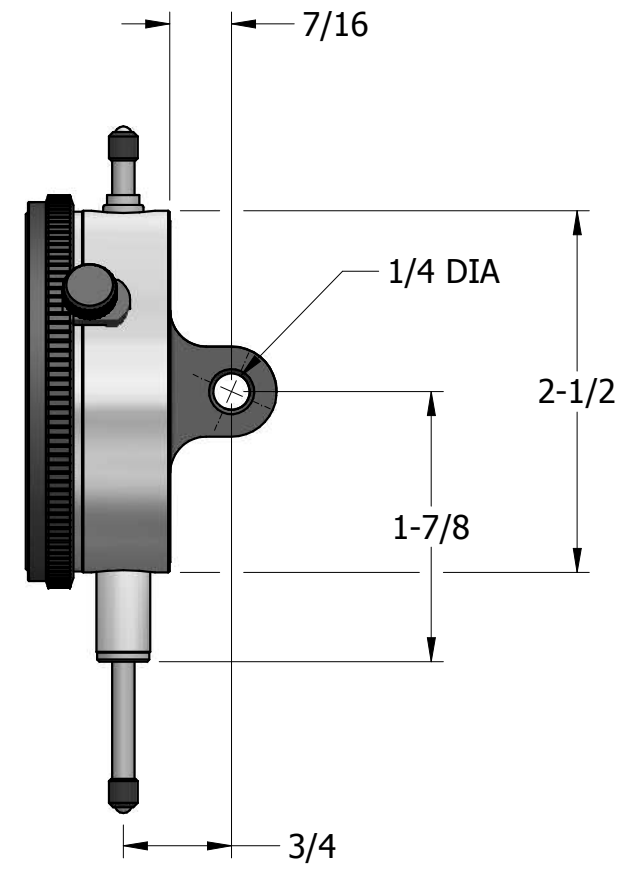
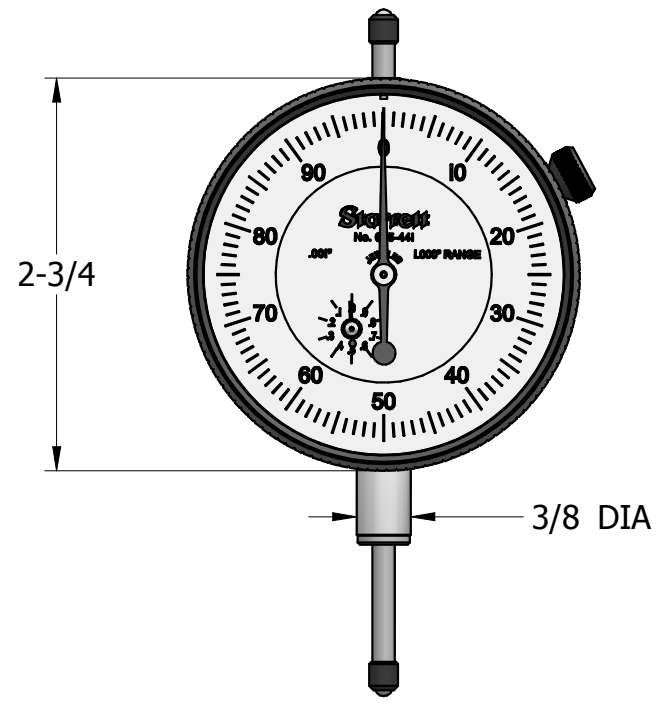
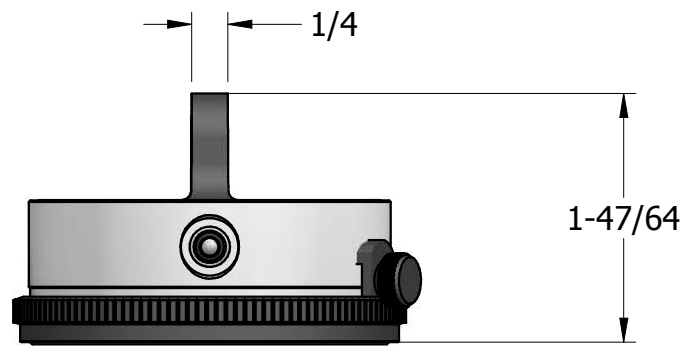

REV	DESCRIPTION	DATE	BY
DR	HB	CHK	DATE 9-27-54

**CASE ASSEMBLY  
1.000 RANGE  
2 GEAR MODEL**

**THE L.S. STARRETT CO.  
ATHOL, MASS.**

FRACTIONAL TOLERANCE +- 1/64 UNLESS OTHERWISE NOTED